

# Environmental Design Principles for the Building Envelope and More \_

## Passive and Active Measures

Thaleia Konstantinou<sup>1\*</sup> and Alejandro Prieto<sup>1</sup>

\* Corresponding Author

<sup>1</sup> Faculty of Architecture and the Built Environment, Delft University of Technology, The Netherlands, t.konstantinou@tudelft.nl

### ABSTRACT

**Given the need to reduce building sector related energy consumption and greenhouse gases (GHG), passive and sustainable buildings are a focal point. Simple methods and techniques, which use appropriate building design, material and systems selection, and reflect consideration of the local environmental elements, such as air and sun, provide thermal and visual comfort with less non-renewable energy sources. These techniques are referred to as environmental or bioclimatic design. There are two types of measures to be taken: passive and active. Passive principles exploit the design and properties of the building envelope to minimise or maximise the heat losses and heat gains respectively, to reduce the energy demand. In addition to passive, active measures such as heating systems and solar power technologies are used to produce and distribute the energy needed to achieve comfort of the occupants.**

**The present chapter aims at giving an overview of design principles that result in more comfortable and energy efficient buildings. Passive and active design principles are in line with the environmental design concepts. The environmental design principles can be beneficial to the building performance, whether the design ambition is to have a comfortable and functional building with reasonable energy demand or goes as far as achieving sustainable standards such as zero-energy or passive house.**

KEYWORDS environmental, bioclimatic design, passive, active

## 1 Introduction

Due to the need to reduce the energy demand and the related GHG, passive and sustainable buildings that use less non-renewable energy sources is a focal point. To achieve this, we can apply simple methods and techniques, starting with an appropriate building design, and material and systems selection, which make use of environmental elements such as the air and the sun, to provide thermal and visual comfort to occupants. These techniques are often referred to as environmental or bioclimatic design. Such ideas have existed since man first sought for shelter. As a term, however, bioclimatic design was identified and developed in the 1960s. Bioclimatic issues, including occupants' thermal comfort and passive, low-energy architecture have been a starting point for designing new buildings and refurbishment projects.

There are two courses of measures to be taken: passive and active. On the one hand, passive measures are principles that exploit the design and properties of the building envelope to reduce the energy demand, by maximising or minimising heat losses and heat gains. On the other hand, active systems are used to produce and distribute the energy needed to achieve comfort of the occupants. The use of waste energy should also be considered on a building or neighbourhood scale.

The present chapter aims at giving an overview of passive and active design principles that can be applied to the design of the building envelope and the system selection, resulting in more comfortable and energy efficient buildings. Firstly, general guidelines and possible classification of these strategies are discussed, focusing on hierarchical models to assist in the design process. A hierarchical approach to sustainability suggests, firstly, the prevention of energy use; then, renewable energy sources use as widely as possible; and finally, efficient use of fossil fuels. Subsequently, it is explained which passive and active design principles are in line with the environmental design concepts and how they are implemented. The chapter concludes with an explanation of how the application of such measures can be evaluated based on climate characteristics.

## 2 A Hierarchical Approach to Sustainable Design

Several authors have discussed the implementation of energy-saving strategies, organising them according to several parameters. Lechner proposed a three-tier design approach for sustainable buildings in 1991 [Lechner, 2014]. The first tier deals with basic building design strategies such as orientation, insulation, and the use of exterior shading. If this is insufficient to meet the requirements, which is often the case in warm climates, then the second tier of passive or hybrid systems should follow. This second level is based on natural energies and considers the use of evaporative cooling, earth coupling, or diurnal/nocturnal ventilation. Lastly, mechanical equipment could be incorporated into

the building in the third tier, if needed, within an already passively optimised building design.

Similarly, Herzog, Krippner, and Lang (2004) defined two sequential sets of strategies to cope with the regulatory functions of the façade. As a first resource, the authors considered the application of measures such as thermal insulation, sun shading or even vegetation; they then suggested the use of supplementary building services such as artificial lighting and air conditioning, only if needed. The authors also considered the use of thermal collectors or PV panels for energy generation, which relates to the hybrid use of natural energies expressed by Lechner as an alternative to the use of fossil fuels.

“Trias Energetica” as a concept was introduced by Lysen in 1996 (AgentschapNL, 2013) and is based on Duijvestein’s (1993) three-step scheme, which ranked sustainable measures for the building industry. The scheme was as follows: firstly, prevent the use of energy (prevention); then, use renewable energy sources as extensively as possible (renewable); finally, if still needed, use fossil fuels as efficiently as possible (efficiency). The Trias Energetica was adopted internationally, starting in 2001 by the former president of the ‘International Solar Energy Society’ (Entrop & Brouwers, 2010). For zero-energy buildings and homes in particular, the third step suggests using finite energy sources very efficiently and compensating them with 100% renewable energy (AgentschapNL, 2013).

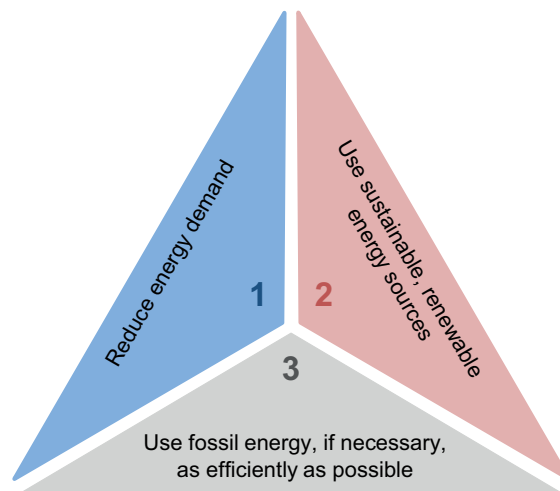

FIG. 2.1 The “Trias Energetica” principle

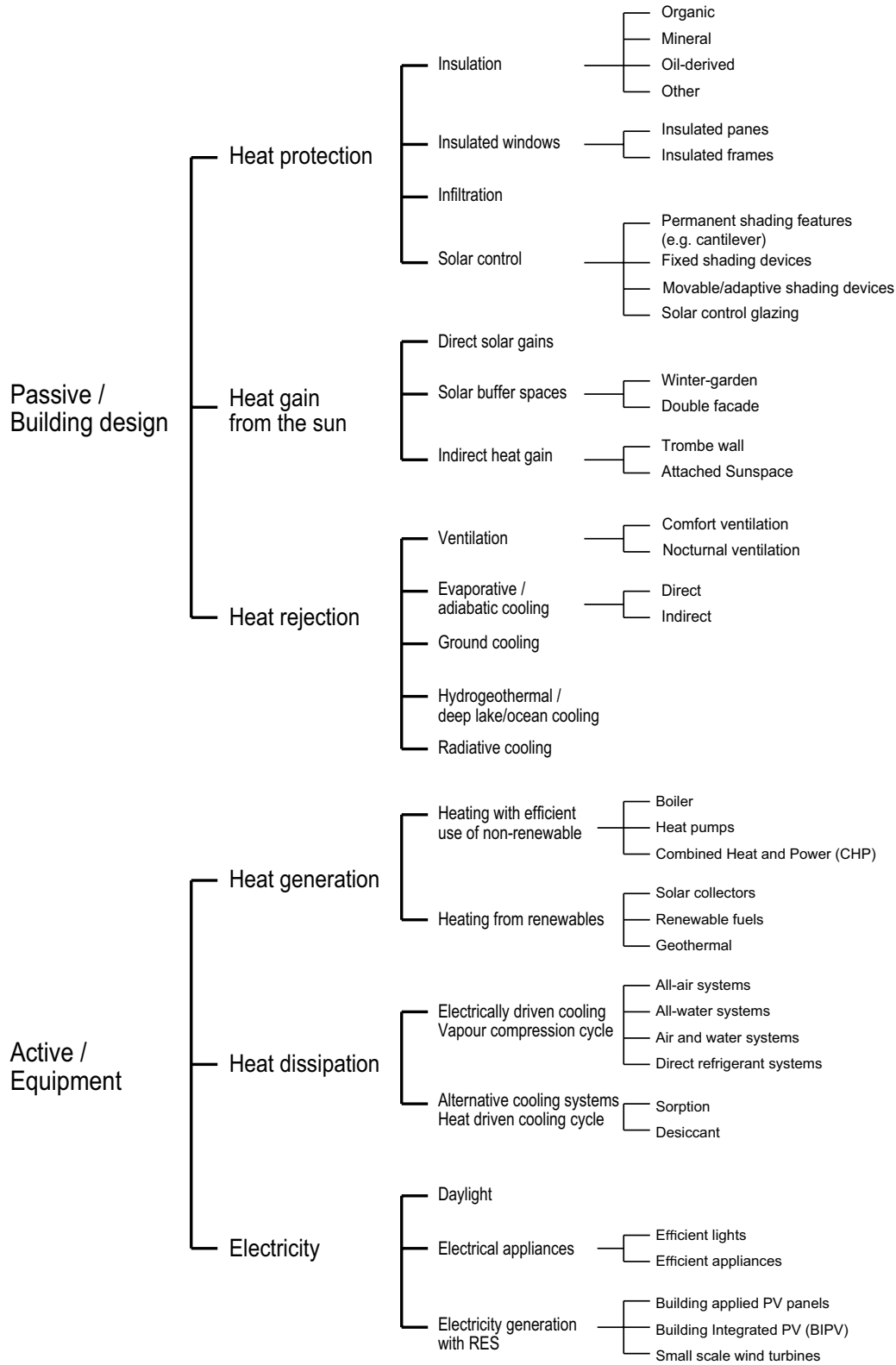

FIG. 2.2 Overview of the passive and active measures and their objective, within the scope of environmental design

More recently, the New Stepped Strategy (NSS) has substituted the Trias Energetica. This strategy adds a significant step between minimising the demand and the use of renewable sources, and it incorporates a waste stream strategy inspired by the Cradle-to-Cradle principle.

The previous last step, which implied accepting the use of fossil fuels, becomes obsolete (van den Dobbelsteen, 2008).

Whatever the approach, the common thread is that the measures that need to be considered during environmental design can, generally, be characterised as passive or active. Passive measures are related to the building design and the properties and function of the building envelope, while active measures include the use of mechanical equipment. The objective for both passive and active measures is to enhance the heat flow in and out the occupied spaces, towards the ultimate goal of achieving thermal comfort. Fig. 2.2 provides an overview of the measures and their objective. The next sections of this chapter explain the principles, following the proposed classification of passive and active measures.

### 3 **Passive/ Building Design Strategies**

Passive design principles aim at minimising the energy demand of the building. Proper consideration of the local climate and environmental elements, building layout, and material properties make the energy demand reduction possible. Passive principles can be classified in the following basic functions: heat protection, solar heat gain, and heat rejection.

#### 3.1 Heat Protection

In order to reduce the energy demand, the building envelope should prevent, or at least minimise, heat flow due to the temperature differences. In winter, the flow goes from the inside to the outside, and vice versa during summer, when outside temperatures are higher than the interior temperature. A low thermal transmittance of the components is, thus, essential during all seasons. Increasing the airtightness and thermal resistance of the building envelope with the use of insulating materials for opaque elements of the envelope and insulated windows for the openings is the main strategy for heat protection.

##### 3.1.1 Insulation

A material with a high thermal resistance that opposes heat transfer between areas with temperature differences is considered an insulator (McMullan, 2002, p. 37). Such materials, mostly used on the opaque building components, can improve the thermal and sound insulation of the building. They reduce transmission heat losses and produce higher surface temperatures (Hausladen, Saldanha, & Liedl, 2008).

	INSULATION MATERIAL	DENSITY $\rho$ (kg/m <sup>3</sup> )	THERMAL CONDUCTIVITY $\lambda$ (W/(mK))	WATER VAPOUR DIFFUSION RESISTANCE INDEX $\mu$	FIRE RESISTANCE CLASS EUROCLASS	FORMS AVAILABLE	APPLICA-TIONS	INSULATION THICKNESS FOR U-VALUE 0.2 W/(m <sup>2</sup> K)	EMBODIED ENERGY MJ/ kg
ORGANIC	Flax	20-50	0.038-0.045	1-2	E	Batts, blown material, loose fill	exterior wall, cavity, ETICS, floor, loft, roof	18-20 cm	11-30
	Hemp	20-50	0.038-0.045	1-2	E	Batts, blown material, loose fill	exterior wall, cavity, ETICS, floor, loft, roof	18-36 cm	10.5-33
	Wood fibres	150-250	0.040-0.081	2-5	E	Boards, blown material	exterior wall, cavity, ETICS, floor, loft, roof	18-36 cm	17
	Wood-wool boards	60-600	0.080-0.100	2-5	E	Boards	exterior wall, cavity, ETICS, floor, loft, roof	40-45cm	10.8
	Cork	100-120	0.038-0.050	10-18	E	Granulate, board	exterior wall, cavity, ETICS, floor, loft, roof	18-25	26
	Reed	155	0.040-0.065	2	E	Batts	exterior wall, floor, loft, roof	20-29	
	Sheep's wool	20-50	0.040-0.044	1-2	E	Batts, blown material	exterior wall, cavity, ETICS, floor, loft, roof	18-20	20.9
	Cellulose	25-66	0.040-0.045	1-2	E	Loose fill, blown material	exterior wall, cavity, ETICS, floor, loft, roof	18-20	7,6
MINERAL	Rock wool	20-40	0.031-0.040	1-2	A1	Batts, blown material, boards	exterior wall, cavity, ETICS, floor, loft, roof	16-22	16,8
	Glass wool	16-25	0.031-0.040	1-2	A1	Batts, blown material, boards	exterior wall, cavity, ETICS, floor, loft, roof	16-22	49,6
	Mineral foam	70	0.035-0.051	3-5	A1	Board	exterior wall, ETICS, floor, loft, roof	16-20	
	Perlite	60-160	0.040-0.060	5-25	A1	Loose fill	exterior wall, cavity, floor, loft	25	
	Cellular or foam glass	10-120	0.040-0.055	$\infty$	A1	Loose fill, board	exterior wall, cavity, ETICS, floor, loft, roof	18-25	26
	Aerogel	180	0,013	$\infty$	A	Batts, granulate, monolithic	exterior wall, loft, roof	6,5	53
OIL-DERIVED	Expanded polystyrene (EPS)	15-30	0.035-0.040	20-100	D to F	Board	exterior wall, ETICS, loft, roof	16-18	108
	Extruded polystyrene (XPS)	20-50	0.030-0.040	5-23	E	Board	exterior wall, ETICS, floor, roof	13-18	95
	Polyurethane	30-40	0.025-0.040	30-100	C (B for Metal faced sandwich panels )	Board (PUR/PIR), in situ foam	exterior wall, cavity, ETICS, floor, loft, roof	11-18	101
OTHER	Vacuum insulation panels (VIP)	150-180	0.07-0.10 W/ (m K)	$\infty$	A (for VIP core)	Panels	exterior wall, floor, loft	3-4	81.9
	Transparent insulation			5-26		Board	exterior wall		

TABLE 3.1 Typical insulation materials (Konstantinou, 2014, Table 4.3)

The insulating effect is the result of the low thermal conductivity of air that is enclosed in the porous material. There is a bewildering range of insulating materials, from the familiar polystyrene and mineral wool to alternative materials that are gradually establishing themselves in the market such as sheep's wool and hemp. Table 3.1 presents typical insulation materials organised firstly according to the origin of the raw material, and then classified into organic, inorganic/mineral, or oil-derived types. Moreover, insulation technologies can be artificially manufactured, such as vacuum insulation panels. Additional information about specifications, form, and applications for the different materials is also provided (AEA, 2010; Giebeler, 2009; greenspec, 2013; Lyons, 2010; Papadopoulos, 2005).

Besides thermal and moisture related properties, other parameters that determine the final choice of insulation material are fire resistance, sound insulation and mechanical properties, cost, suitability and ease of installation, environmental properties and pollutants content, and production process and chemical composition.

Depending on their form, they are subdivided into fibre, foamed, and granulate or loose fill insulation (Hausladen et al., 2008). The adequacy of the various insulation material depends on the application. Loose materials can be inserted between wooden posts and beams or, more generally, in structurally hollow spaces. Insulating panels or matting are cut to size and can then be installed accurately. Rigid foam insulation boards are appropriate for external applications, due to higher impact strength.

### 3.1.2 Insulated Windows

Openings are an integral part of the building envelope, serving view, daylight and ventilation. These openings are usually operable and made of transparent material, mostly glass, to fulfil their functions. One of the shortcomings of glass are its relatively poor thermal properties. Nevertheless, technology provides the opportunity to use insulated windows, consisting of panes and frames with lower thermal conductivity.

Over the last decades, multiple panes of glass separated by air spaces have replaced single glazed window panes, resulting in significant improvement of the window insulation value. Additionally, if the cavity between the panes is filled with a less conductive, slow-moving gas, such as argon or krypton, the conductance of the cavity is even further reduced, which improves the thermal performance of glazing units.

Moreover, low-emissivity coatings, called Low-E for short, are used to reduce the surface emissivity of glass. Such coatings consist of a microscopically thin metal oxide or semiconductor film, and they are applied on the faces between the panes, facing the cavity. They are mainly transparent across the visible wavelengths of light but reduce the long-wave infrared thermal radiation that is absorbed and emitted

by the glass pane. This reduces heat loss because the re-emission is directed to the interior of the building if the coating is on the outside face, as is advised for cold climates. In a hot climate, the coating should be placed on the inside face, so that the solar radiation is reflected to the environment (Fig. 3.1).

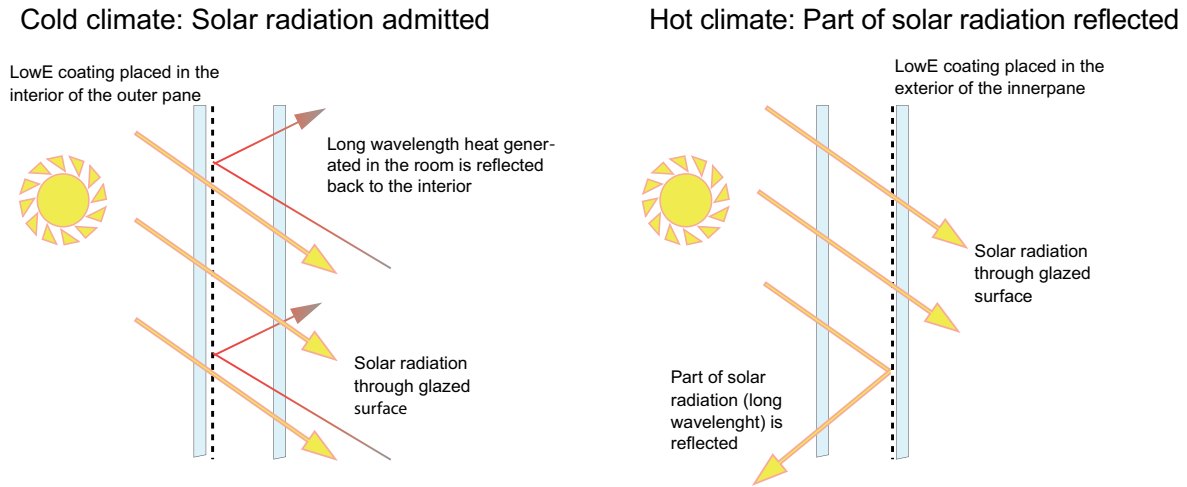

FIG. 3.1 Scheme of coating placement

Thermal transmittance coefficient or *U-value* is typically used to evaluate the window pane performance. The overall thermal conductivity depends on the number of panes, the depth of the cavity, the gas infill, and the coating. Table 3.2 compares glazing types with different characteristics. The values given in the table may vary for specific products. However, they aim at indicating the thermal performance of the glazing according to its specifications.

GLAZING	NUMBER OF PANES	GAS INFILL	DIMENSIONS (mm)	U-VALUE (W/(m <sup>2</sup> K))
Single glazing	1	n/a	4	5.6
Double glazing	2	Air	4-6-4	3.3
Double glazing	2	Air	4-12-4	2.8
Triple glazing	3	Air	4-6-4-6-4	2.3
Triple glazing	3	Air	4-12-4-12-4	1.9
Double glazing with Low E coating	2	Air	4-6-4	2.5
Double glazing with Low E coating	2	Air	4-12-4	1.7
Triple glazing with 2Low E coatings	3	Air	4-6-4-6-4	1.6
Triple glazing with 2Low E coatings	3	Air	4-12-4-12-4	1.0
Double glazing with Low E coatings and Argon	2	Argon	4-6-4	2.1
Double glazing with Low E coatings and Argon	2	Argon	4-12-4	1.3
Triple glazing with 2Low E coatings and Argon	3	Argon	4-6-4-6-4	1.2
Triple glazing with 2Low E coatings 2 and Argon	3	Argon	4-12-4-12-4	0.8

TABLE 3.2 Comparison of typical heat transfer through different glazing options (source: ISO10077-1, 2006, p. 18, table C.2)



As glazing and wall thermal performance improves, the window frame can create thermal bridging problems. To overcome this issue and reach requirements for higher efficiency of the building envelope, thermal breaks within the window frame profile are introduced. Some of the materials used are ABS (acrylonitrile butadiene styrene), polyethylene HD, polyamide (nylon), PVC-U (polyvinylchloride), polypropylene, and polyurethane (ISO10077-2, 2006). A definition of the thermal transmittance of the frame section  $U_f$  considers the thickness of the frame material, the thermal break material, the glazing, and the sealant.

Window frames are made of different materials, as shown in Table 3.3. Most commonly, window frames consist of timber, aluminium, steel, or plastic. The choice of the frame type depends on the properties and cost of the material, as well as the desired architectural expression.

MATERIAL	SCHEMATIC SECTION *	PROPERTIES	LIMITATIONS	THERMAL CONDUCTIVITY, $\lambda$ W/(mK)*
<b>Timber</b>		Psychological/aesthetic effect as a "warm" material Low embodied energy Good thermal behaviour	Need regular maintenance Special considerations against water penetration, mould and insect infestation	0.13
<b>Timber/ aluminium</b>		Aluminium cladding covering the entire exterior of the frame Weather protection Psychological/aesthetical effect as a "warm" material in the interior	Need regular maintenance Special considerations against water penetration, mould and insect infestation	See thermal conductivity for timber and aluminium
<b>Aluminium</b>		Extruded profiles Structural integrity Precise and airtight construction Easy maintenance	High thermal conductivity. Thermal break needed. High initial cost High embodied energy	160
<b>Steel</b>		Profiles made of folding sheet metal High bending and torsion strength Good fire protection properties	Thermal break required High cost Corrosion protection needed	50
<b>Plastic (uPVC)</b>		Extruded profiles Impact and scratch resistance Low cost Easy installation and maintenance Resistant to water and corrosion	Prone to heat deformation Not fire resistant Limited structural strength	0.17

TABLE 3.3 Window frame types (Konstantinou, 2014, Table 4.5)

\*adapted from ISO10077-2 (2006)

### 3.1.3 Infiltration

Infiltration, or air leakage, is the movement of air through leaks, cracks, or other adventitious openings in the building envelope (Sherman & Chan, 2004). Air-tightness is the fundamental building property that affects infiltration. From the energy perspective, air leakage is one of the leading causes of heating energy loss, as it allows heated air to escape the conditioned spaces. Even with current standards for air-tightness, envelope leakage can increase the heating needs by 5-20 kWh/(m<sup>2</sup>a) in a moderate climate (BPIE, 2011, p. 51). Moreover, it degrades the effectiveness of the insulation and allows potentially damaging moisture to penetrate the building envelope. Air leakage occurs at joints of the building fabric, around doors and windows, cracks in masonry walls etc., as well as where pipes and cables pass through the building (Hall, 2008a, p. 49). Nevertheless, the quest for air-tightness must be coupled with an appropriate ventilation system to introduce fresh air in a controlled manner, preserving adequate indoor air quality levels.

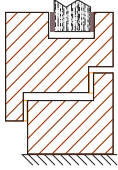
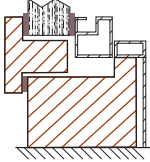
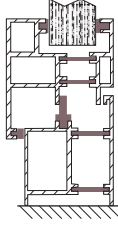
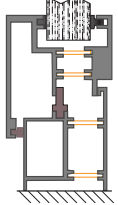
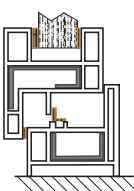
The values can be defined in standards and regulations as n (vol.h) or air flow/outer envelope or air flow/floor area, for a pressure difference of 50 Pa or 10 Pa or 4 Pa. Another unit to measure infiltration and ventilation is air change per hour (ACH), which refers to how many times the air is replaced within a defined space, e.g. a room. High air-tightness requirements for energy-efficient buildings indicate around 1.2 ACH at 50Pa (EN15242, 2007) and 0.6 ACH for the passive house standard. In existing buildings, values up to 16 ACH at 50Pa have been measured (Stephen, 2010), suggesting that the building stock's airtightness should significantly improve.

Careful implementation of strategies throughout the design and construction phases achieve adequate air-tightness. The materials and their application depend on the type of leakage. Air-barrier membranes and sealants, such as expanded foam, gun-applied sealants, tapes, and fillers, should be applied to prevent uncontrolled air and water flow.

With regard to windows, air leakage occurs around the window frame, at the wall connections, and between the operable parts of the frame. Leakage at the wall-frame connection may account for as much as 14% of the total leakage. This source of air leakage can be tackled by applying casing tape, poly-return, poly-wrap and foamed-in-place urethane, and other sealing methods (Sherman & Chan, 2004). Some materials used for weather stripping and sealing the edge of the windows are indicated in ISO10077-2 (2006).

### 3.1.4 Solar Control

Even though solar radiation is welcome during winter, as will be explained in Section 3.2, it should be excluded during summer to avoid overheating of the occupied spaces. The best solar control is proper external sunshade, intercepting direct solar radiation before it strikes the window of a given wall. Shading systems can vary significantly in design, size, and placement, ranging from simple Venetian blinds to more advanced and complicated systems, which ultimately determine the entire building architecture, such as the example in Figure 3.2. The choice depends on the desired performance, functional and aesthetic result. For instance, external shading is more efficient than internal shading, even though it requires higher maintenance.

Shading systems are commonly classified according to their control possibilities, thus separated in movable and fixed systems. The first system offers the user more options but incurs high maintenance costs, while the second are thought to be more efficient (if well designed) but consider no possibility of control from the user and can exhibit varying performance during the day. The movable systems are often referred to as adaptive because they adapt to the changing internal or external conditions.

Orientation is a major factor in determining the shading type. Horizontal screening louvres exclude direct sunlight on the south side with little visual interference. Permanent building elements such as cantilevers function as seasonal solar screening. They block the high angle sun rays in the summer, while they enable solar heating during the winter by allowing lower angle sun rays to penetrate the room. On east and west façades, movable vertical louvres are preferable because the sun strikes at low altitudes. By setting the angle of the louvres accordingly, sunlight can be blocked while retaining some of the view (Hausladen et al., 2008).



FIG. 3.2 Al-Bahr Towers, Abu Dhabi.  
The Mashrabiya as seen from the inside  
– Sky garden open space (Photograph  
by Abdulmajid Karanouh, Ramboll  
(Karanouh & Kerber, 2015))

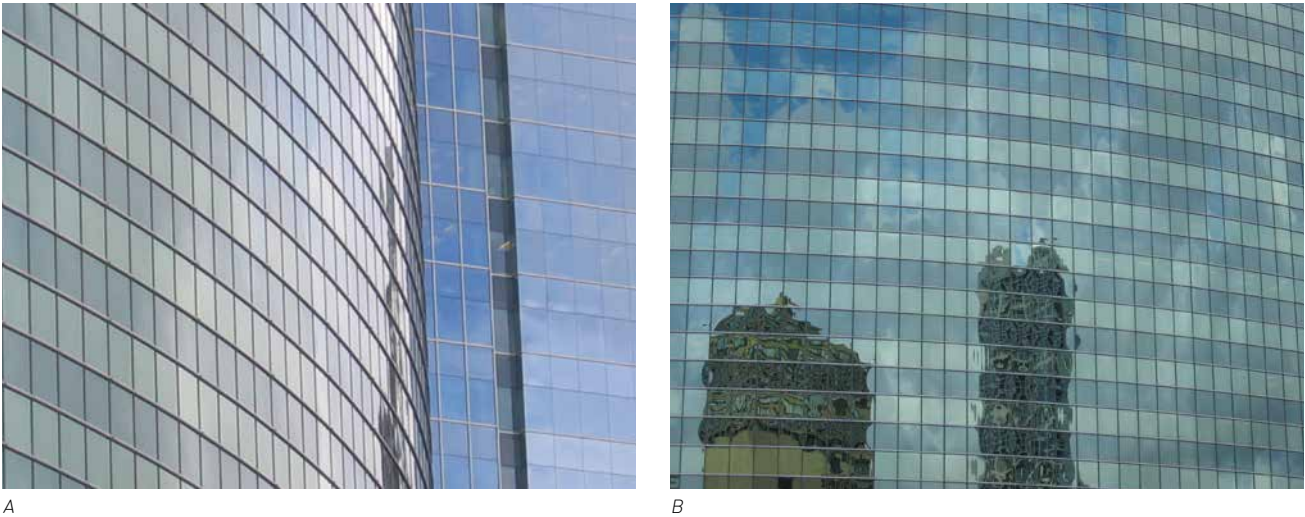

FIG. 3.3 A+B: Reflective glazing in office buildings. Chicago, USA

Moreover, avoiding the admittance of excess solar radiation can be achieved with the use of special glazing, such as tinted, coated or switchable glazing. Glazing can become tinted with small additions of metal oxides to the float or rolled glass composition, which would colour the glass bronze, green, blue or grey but would not affect its basic properties, except changes in the solar energy transmittance.

Chromogenics is a technology of switchable glazing. It refers to glazing in which transmission properties can be regulated by a reversible change of the glass from darker to lighter, or transparent to translucent. Such technologies include photochromic glass that encompasses coatings of silver halide, which changes from clear to dark depending on incident sunlight, while thermochromic glass has a coating of vanadium oxides which exhibit a reversible semiconductor-to-metallic phase transition when the temperature rises (Soltani, Chaker, Haddad, & Kruzelecky, 2008). Electrochromic glazing is a technology of switchable glazing, which is more controllable, as it is coated with tungsten trioxide that changes from clear to dark when electrical current is applied. The effect is that the glazing switches between a clear and a transparent blue-tinted state with no degradation in view, as is shown in Fig. 3.4. Typical EC windows have an upper visible transmittance range of 0.50-0.70 and a lower range of 0.02-0.25.

Finally, another technology of switchable glazing that is gaining popularity is the Liquid Crystal Window. When an electrical current is applied to the thin layer of liquid crystals placed between the panes, the crystals are being rearranged and, as a result, the transmission of the window changes from bright to dark, while maintaining its transparency, as shown in Fig. 3.5. The windows can switch to all intermediate states in-between bright and dark. The *g-value* of the windows ranges between 0.45-0.09.



A

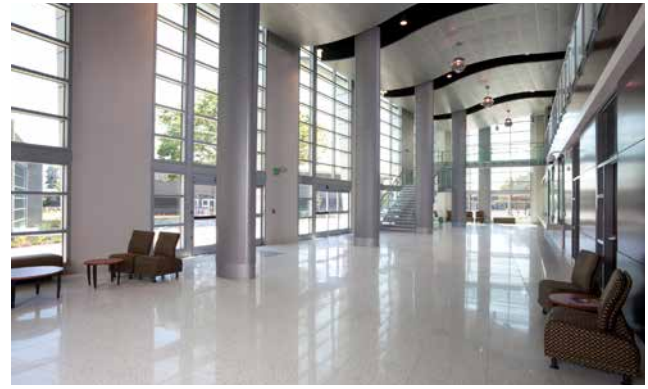

B

FIG. 3.4 A+B Example of chromogenic glazing (photo courtesy of SAGE Electrochromics, Inc., Copyright Eric Sahlin Photography)



FIG. 3.5 Example of Liquid Crystal Window technology (photo courtesy of Merck Window Technologies B.V.)

### 3.2 Heat Gain From the Sun

Passive solar heating is essential during winter when energy for heating is needed for a thermally comfortable indoor environment. It employs transparent elements of the building envelope to collect, store and distribute solar energy without or with the minimum use of mechanical equipment (Hyde, 2008). During summer, when the heating effect is not needed, the glazed parts should be open or protected with adequate shading.

Passive solar heating primarily occurs in the south part of the building – or north for the southern hemisphere. On a dwelling level, this is usually not a big problem, as heat gains can be distributed in short distances and reduce the overall heating loads. In larger buildings, however, it is possible to require zoning in the energy use for different orientations (Hall, 2008b). Moreover, since the windows are one of the primary sources of fabric heat losses, the heat gains through the windows must outweigh the heat losses.



### 3.2.1 Direct Solar Gains

In buildings, sunlight is directly collected through the glazed areas of the façade, especially the equator-facing surfaces. The specific physical properties of glass allow for using solar radiation to heat the interior space. The heating effect is based on the principle that glass is permeable for short-wave radiation (ultraviolet radiation) from the sun but impermeable for the long-wave heat radiation, which is emitted by the materials. The orientation, the positioning and size of the transparent areas, as well as the interior layout for thermal zoning determine the effectiveness of the direct solar heating (Hegger, Fuchs, Stark, & Zeumer, 2008).

### 3.2.2 Solar Buffer Spaces

Solar buffer space is an intermediate space between the occupied, interior space and the exterior. This space is unconditioned and heated exclusively by solar irradiation. As the temperature in the buffer space is higher than the external temperature, the transmission heat losses of the interior are reduced. In dwellings, such spaces are also referred to as winter-gardens, because the temperature in the buffer space can be within comfort levels for a larger percentage of the year, due to solar heat gains. In this way, the usable area increases.



FIG. 3.6 The winter-garden of Pret-a-loger, TU Delft Campus, NL

Double façade constructions can also create a buffer space. Double façades include an exterior façade layer, which is separated from the (interior) façade elements that enclose the occupied space. The distance between the interior and exterior façade layers can vary. Depending on the method used to conduct air in the space between the two façades, double-skin façades can be grouped into four main categories (Knaack, Klein, Bilow, & Auer, 2007):

- box-window façade, where the air only circulates within one façade element,
- shaft-box façade, where the air rises in vertical shafts,
- corridor façade, where the air circulates within the gap between the façades horizontally across one storey, and
- second-skin façade, where the air can flow across the entire, unrestricted gap cavity.

Apart from the thermal buffer effect, a double façade has additional functions regarding ventilation (see also section 3.3.1), noise, and wind protection.



A



B

FIG. 3.7 Double façade examples. Post tower, Bonn (A). Stadttor Düsseldorf, Düsseldorf (B)

### 3.2.3 Indirect Heat Gain

Indirect solar heat gain occurs in the form of heat storage in components with high thermal mass, for example when using transparent outer layer and a heat-absorbing element between the incident solar radiation and the space to be heated. Solar energy transmitted through the transparent layer is absorbed by the outer surface of the wall and conducted to the inner surface several hours later, or is conveyed flowing through the air between glazing and wall. Such methods can be of great benefit, especially when combined with air circulation measures, in areas that receive inconsistent solar radiation (Smith, 2005). Well-

known technologies of indirect solar heating are the Trombe wall and the attached sunspaces. Apart from the advantage in energy efficiency, such constructions can have the benefit of enlarging the living space.

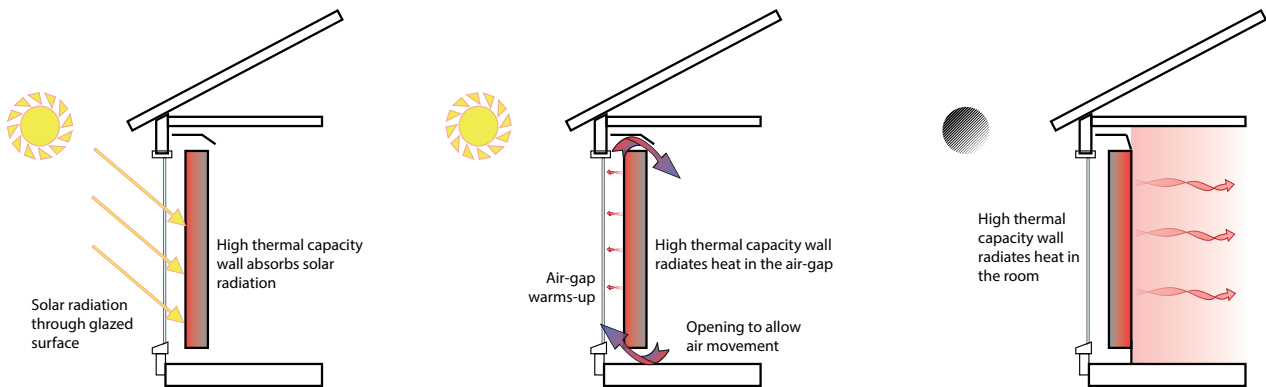

FIG. 3.8 Principle of Trombe wall and attached sunspaces

### 3.3 Heat Rejection

As previously stated, the use of solar control strategies is a highly effective method of preventing heat from entering the building, minimising the occurrence of overheating, and thus, reducing overall cooling demands. However, the presence of internal heat gains and unwanted solar gains, even using optimised shading systems (due to diffuse solar radiation), mean that heat prevention strategies alone are not usually enough to lower indoor temperatures to comfort levels, particularly during summer season. Hence, it is important to consider passive strategies aimed at dissipating heat generated or stored indoors to the external environment (Givoni, 1994; Santamouris & Asimakopoulos, 1996).

Heat rejection or heat dissipation strategies seek to remove indoor heat, releasing it into a natural reservoir (air, water, ground). Passive heat dissipation strategies accomplish this without energy consumption, while their efficiency may benefit from the use of additional equipment such as pumps and fans in so-called hybrid or low-exergy heat rejection systems (Ala-Juusela, 2003; Kalz & Pfafferott, 2014). Moreover, the efficiency of these strategies increases when they work together with heat modulation methods, such as the use of thermal mass for heat storage, to be dissipated to an external heat sink at a more suitable moment, such as night time (Hegger et al., 2008, p. 98). Heavyweight construction, such as concrete, terracotta, and limestone, can provide sufficient thermal mass. Nevertheless, for the thermal mass to be effective, the components need a direct link to the interior. Internal linings and suspended ceilings prevent the heat flow between the air temperature and the building thermal mass. Alternatively, Phase Change Materials (PCM) may be used instead of massive constructive elements for heat storage purposes.

Heat dissipation strategies may be classified according to the heat sinks they employ as base for their cooling principle (Samuel, Nagendra, &



Maiya, 2013). Hence, the use of the ground, air, and water in proximity to the building, and outer sky as heat sinks defines specific heat dissipation possibilities, as shown in Fig. 3.9. As mentioned above, in most cases, an efficient application of these strategies relies on the use of auxiliary mechanical equipment. Therefore, the subsequent description will focus on the passive cooling principles behind each strategy, without detailing further use of active components, such as pumps and fans, for their application in the built environment. Nevertheless, ventilation strategies will be explored in detail, due to their energy savings potential and simplicity of implementation under purely passive operation.

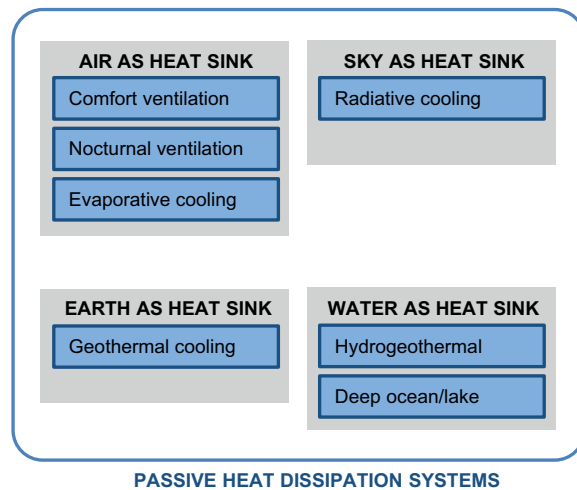

FIG. 3.9 Passive/low-ex heat dissipation strategies according to the heat sinks used for their cooling principle

### 3.3.1 Ventilation

Ventilation is the most common heat dissipation strategy, using external air as a heat reservoir to lower indoor temperatures. Two main strategies are distinguished based on the principle: comfort or diurnal ventilation, and nocturnal or night-flush ventilation. The former acts during peak demands, improving users’ perceived comfort, while the latter operates at night time, rejecting stored heat to cool down the building for the next day. High temperatures during daytime may be counterproductive for the application of comfort ventilation, but research has shown that building occupants are willing to accept higher indoor temperatures if they have access to natural ventilation, promoting its use under adaptive comfort control models (Nicol, Humphreys, & Roaf, 2012). Fig. 3.10 shows the different ventilation strategies.

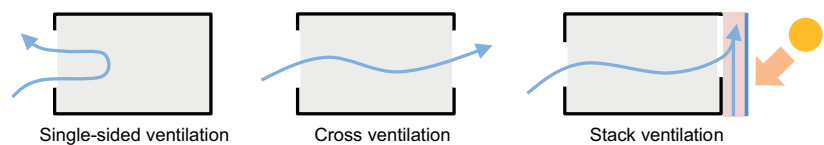

FIG. 3.10 Ventilation strategies: single-sided, cross, and stack ventilation

Nocturnal ventilation has been regarded as an efficient cooling method for buildings and has been consistently researched as a particular topic of interest over the last 20 years (Prieto, Knaack, Klein, & Auer, 2017). Some early experiences dealt with the evaluation of these strategies via on-site measurements, while others have used simulations to assess the energy saving potential of their application, discussing possibilities for implementation in different climate contexts (Artmann, Manz, & Heiselberg, 2007; Geros, 1999). Several research experiences have shown potential for cooling demand savings, ranging from 40% to 80%, depending on flow rates, climate context, and particularities of the building (Ferrari & Zanotto, 2012; Roach, Bruno, & Belusko, 2013). Nocturnal ventilation strategies perform better in climates with high thermal oscillation between day and night (more than 10°C), taking advantage of lower night temperatures to release heat stored during the day.

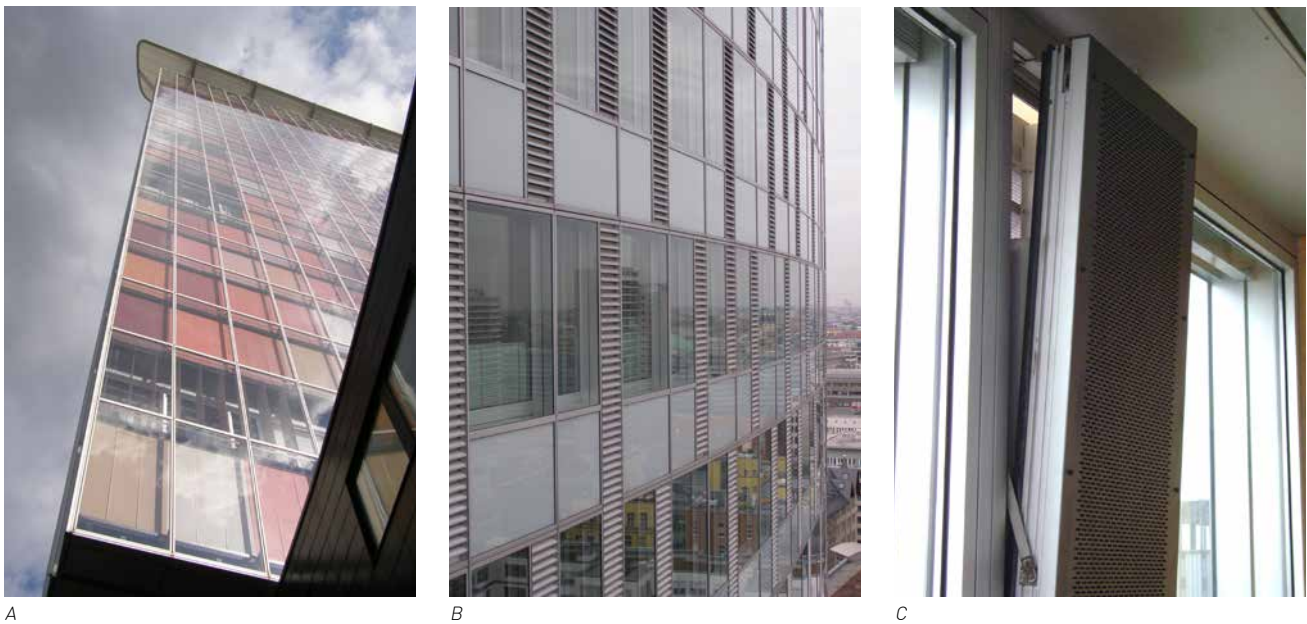

FIG. 3.11 A+B+C: Ventiladed double façade and air inlets for cross-ventilation in the GSW building, Berlin

Nocturnal ventilation has been regarded as an efficient cooling method for buildings and has been consistently researched as a particular topic of interest over the last 20 years (Prieto, Knaack, Klein, & Auer, 2017). Some early experiences dealt with the evaluation of these strategies via on-site measurements, while others have used simulations to assess the energy saving potential of their application, discussing possibilities for implementation in different climate contexts (Artmann, Manz, & Heiselberg, 2007; Geros, 1999). Several research experiences have shown potential for cooling demand savings, ranging from 40% to 80%, depending on flow rates, climate context, and particularities of the building (Ferrari & Zanotto, 2012; Roach, Bruno, & Belusko, 2013). Nocturnal ventilation strategies perform better in climates with high thermal oscillation between day and night (more than 10°C), taking advantage of lower night temperatures to release heat stored during the day.

Natural ventilation (air currents without the use of fans), occurs under two basic principles: wind driven ventilation, and stack or buoyancy driven ventilation. The former relies on wind-induced pressure differentials and air inlets in the building facade, while the latter results from convective flows originated by vertical temperature gradients. The application of different ventilation principles implies design decisions at the early stages of a building project. Room orientations, building layouts, and window size and position are factors to consider to allow for single-sided or cross-ventilation, while architectural elements such as atriums, solar chimneys, and multi-layered facades have been conceived to promote buoyancy driven ventilation specifically.

### 3.3.2 Evaporative / Adiabatic Cooling

Evaporative cooling provides a cooling effect through the evaporation of water. Thus, internal heat gains are used as latent heat for the phase change from water to vapour in the humidity content of indoor air. The effectiveness of the strategy relies on the circulation of air before it reaches humidity saturation levels, releasing warm and humid air to the external environment. These techniques have mostly been researched for hot-arid climate applications, considering them along with ventilation strategies to bring pre-cooled fresh air into the buildings, such as in Fig. 3.12. Nonetheless, their efficiency has been analysed in different climate contexts in order to explore the potential for implementation in other regions (Morgado, Melero, Neila, & Acha, 2011).

The implementation of these technologies follows two possibilities: direct and indirect evaporative cooling systems. Direct systems increase the humidity of the room, directly integrating a water source into space, or mixing it with an air current, while indirect systems keep the water in a closed cycle, with the exception of incoming fresh air. The latter is a more complex system, but its application is suitable for cases where indoor humidity levels are a relevant issue. Building application has sparked the exploration of integration possibilities in façade modules or solar chimneys, in combination with ventilation strategies (Abdallah et al., 2013; Abu Khadra & Chalfoun, 2014).

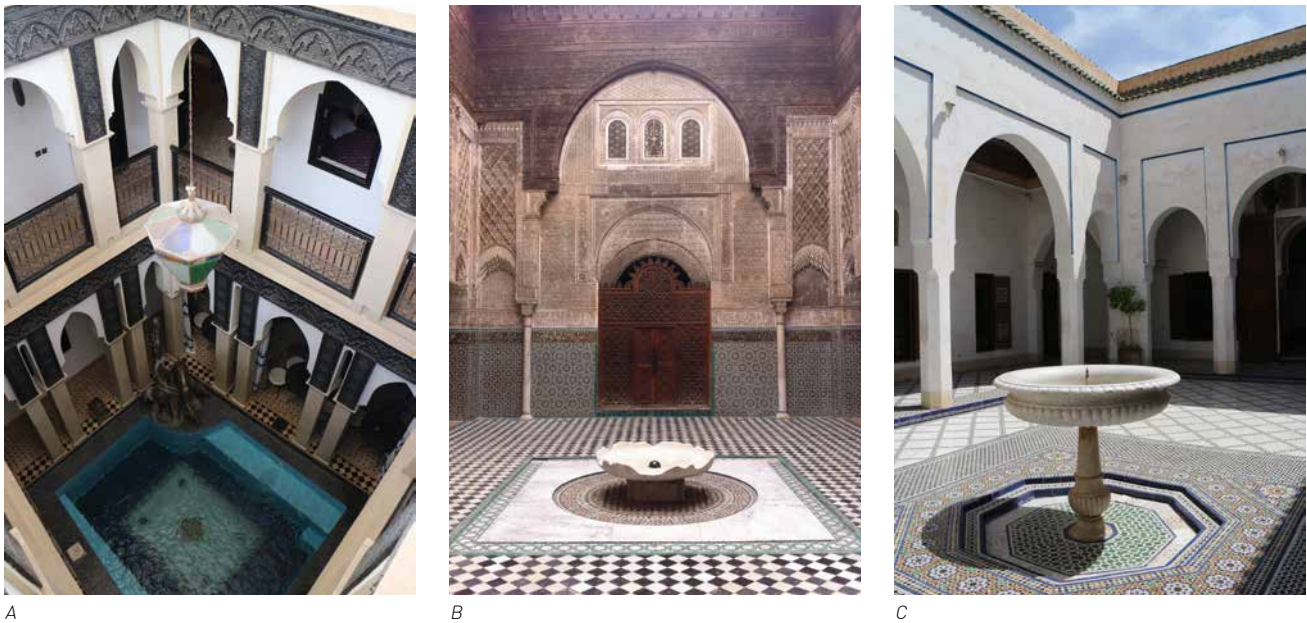

FIG. 3.12 A+B+C: Adiabatic cooling in courtyards, Morocco

### 3.3.3 Ground Cooling

Ground or geothermal cooling uses the earth as a heat sink during the summer season, taking advantage of constant temperatures below 6 meters deep throughout the year. Application of these strategies requires the use of earth-to-air heat exchangers with improved effectiveness when coupled with other strategies such as thermal storage, evaporative cooling, or ventilation by use of solar chimneys. This strategy will be further explored in section 4.1.2 when referring to geothermal heating by use of renewable sources.

### 3.3.4 Hydrogeothermal / Deep Lake / Ocean Cooling

Hydrogeothermal and deep lake/ocean cooling follows the same principle as ground cooling, but uses a large mass of water as heat reservoir instead of the earth. In the first case, underground water is used as a primary source, while the bottom layer of lakes and oceans is used as cooling source for the second one (Samuel et al., 2013). The applicability of these technologies in the built environment is limited, being mostly reserved for large infrastructure or offshore projects. Nonetheless, they are considered in this review for the sake of completeness.

### 3.3.5 Radiative Cooling

Radiative cooling uses the outer space as a heat sink, rejecting heat in the form of electromagnetic radiation at long waves, from surfaces

exposed to the sky during night time (Samuel et al., 2013). Therefore, the roof is regarded as the most important passive radiative cooling element in a building, and design variables such as colour and the use of movable insulation may increase the effectiveness of this strategy (Santamouris & Asimakopoulos, 1996). Radiative cooling strategies achieve higher performances under clear and unpolluted skies, so their use is recommended in hot-dry climate zones.

## 4 Active/ Equipment

Passive design principles alone cannot eliminate energy demand across all seasons. Even after applying passive measures, the additional energy required is provided by the technical building systems, which are the technical equipment for the heating, cooling, ventilation, hot water, lighting, or for a combination thereof.

### 4.1 Heat Generation

#### 4.1.1 Heating with Efficient Use of Non-Renewable Energy

Heating system operation has to cope with heating energy demands of any given indoor space for the indoor temperature to reach thermal comfort levels. Hydronics are systems that use hot water for transferring heat from the heat generator to the heat emitters. The most common type of heat generator for hydronic systems is a 'boiler'. Boilers are available in a broad range of types and sizes and operate with different fuels, such as gas, oil, electricity or biomass. Fig. 4.1 shows the mix of energy sources used for heating in various European countries.

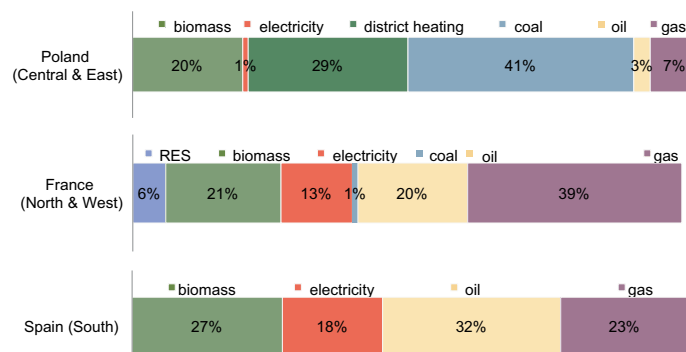

FIG. 4.1 Mix of energy sources used for heating (source: BPIE, 2011)

The efficiency of any given boiler indicates how well it transfers the heat generated during combustion (Hall, 2008b). Boiler efficiency has improved markedly over the past two decades, with efficiencies that reach up to 91% (SEDBUK, 2005). This is an important consideration, particularly in the case of retrofitting, as the older buildings most likely have heating systems with efficiency levels lower than current standards.

EPBD suggests that boilers older than 15 years should be inspected and replaced, and new boilers should be inspected every 2-4 years.

Heat pumps can also generate the hot water for hydronic heating systems. They include a vapour compression refrigeration system or a refrigerant/sorbent pair to transfer heat from the source using electrical or thermal energy at a high temperature to the heat sink (EN15316-4-2, 2007). Heat pumps make use of different sources of low-grade heat. Air source systems (ASHP) offer advantages regarding space requirements and ease of installation, but they cannot offer the same year-round efficiency as other sources. Water source heat pumps (WSHP) provide the best coefficient of performance (CoP), but they require a nearby water source. Ground source heat pumps (GSHP) should not be confused with geothermal energy. GSHP pipes are only buried 1 meter below the surface to use the solar energy stored in the ground. Geothermal energy, on the other hand, is heat within the earth in depths of around 30m (Hall, 2008a). The heat pumps widely used for heating are reversible air-to-air units that can also be used for cooling (CISBE, 2005). These systems will be explored in section 4.2.1, discussing the vapour compression refrigeration cycle.

Hydronic systems can work with different heat emitters, such as radiators, convectors or under-floor heating. The efficiency of the heat emitters and circuit, together with the boiler's efficiency, determine the overall efficiency of the heating system.

Warm air, produced by either stand-alone heaters or a central air-handling plant, is a different heating system. In many cases, the same plant is used for summertime cooling/ventilation. The heat output is provided mostly by convection through the warm air. Such systems have a faster response time than hydronic systems.

Combined Heat and Power (CHP) or cogeneration plants provide simultaneous generation in one process of thermal energy and electrical and mechanical energy. The energy efficiency for building-integrated cogeneration installations ranges, depending on the technology, from 75% to 105%, which means that the energy output can be higher than the input (EN15316-4-4, 2007). CHP schemes may be useful for dense group of properties, such as high-rise flats, or even applied on a community level (Emmanuel & Baker, 2012).

District heating is an efficient way to provide heat, particularly when combined with CHP units. The heat is generated in a central source and delivered in the form of hot water on demand to a group of buildings (Hall, 2008b). Similarly, the same principle may be used during summer, in the opposite direction. However, district cooling applications are scarcer.



#### 4.1.2 Heating from Renewables

Heat can be generated from renewable sources, for example through active solar systems or biomass. An active solar thermal system (e.g. from evacuated solar heating panels) combined with large hot water storage to supply domestic hot water (DHW) and heating, is an efficient solution, particularly in the summer. Solar collectors convert direct solar radiation into other forms of energy, i.e. they preheat water using a closed-circuit clarifier. The different types of solar collectors depend on the system construction. Evacuated solar heating panels are more efficient than conventional flat plate type collectors and perform better in cold, cloudy, and windy conditions. The higher efficiency of evacuated solar heating tubes means less surface area is needed on the roof.

Moreover, there are heating systems that use renewable fuels, such as biomass. Biomass is organic substance. In the energy context, biomass is considered a renewable raw material that provides energy without producing additional amounts of CO<sub>2</sub> within its life cycle, as the amount of CO<sub>2</sub> released has already been absorbed by the plants during growth. Therefore, it is considered a CO<sub>2</sub> neutral source and the primary energy factor of biomass is lower compared to other fuels (Hegger et al., 2008). Modern biomass heating systems are an alternative to fossil fuel systems, and they are as efficient and easy to use as conventional systems. There can be various renewable sources used as fuel in modern heating systems, predominantly wood (in the form of pellets or wood chips, such as the ones shown in Figure 4.2), but also vegetable oil or biogas. The characteristics of the biomass fuel determine how the system performs.



FIG. 4.2 Biomass boiler (A), wood pellet (B) and wood chips (C) (Image source courtesy 3N e.V.)

Geothermal heating is based on the principle that the temperature in the ground is constant at a deeper depth, and beyond approximately 30m it corresponds to the average air temperature (Hegger et al., 2008). Water that is pumped down a borehole into the ground and back to the surface transfers the heat by simple conduction from the ground to the water, which is then used to heat the building.

## 4.2 Heat Dissipation – Ventilation and Cooling

If the use of passive cooling strategies does not suffice to guarantee comfortable temperatures during the summer season, the use of building services should include complementary mechanical cooling system. The use of such systems is common in warm climates, and particularly necessary in commercial buildings, due to high internal heat gains because of occupation, lighting, and office equipment. Studies have shown that refrigeration and air-conditioning are responsible for about 15% of the total electricity consumption in the world (CICA, 2002), and their consumption share in office buildings may reach up to 50% of the total energy demands in hot and humid environments (Qi, 2006). It is important to understand their functioning principles and basic components to appropriately consider them in terms of building design, preventing oversizing, and extra energy expenditure.

### 4.2.1 Electrically Driven Cooling: Vapour Compression Cycle

A mechanical cooling system comprehends five elements/stages: the room to be conditioned, heat transfer equipment, the refrigeration machine, heat rejection equipment, and the external heat sink. Cooling generation is based on thermodynamic cycles. The most frequently used system is the vapour compression cycle, which represents over 90% of all installed systems. The working principle is based on the compression and subsequent expansion of a circulating liquid refrigerant in a closed cycle. The expanded refrigerant evaporates in contact with indoor air, absorbing ambient heat. After being compressed, releasing the latent heat into the environment, the heat later condenses outdoors, to restart the cycle (Fig. 4.3).

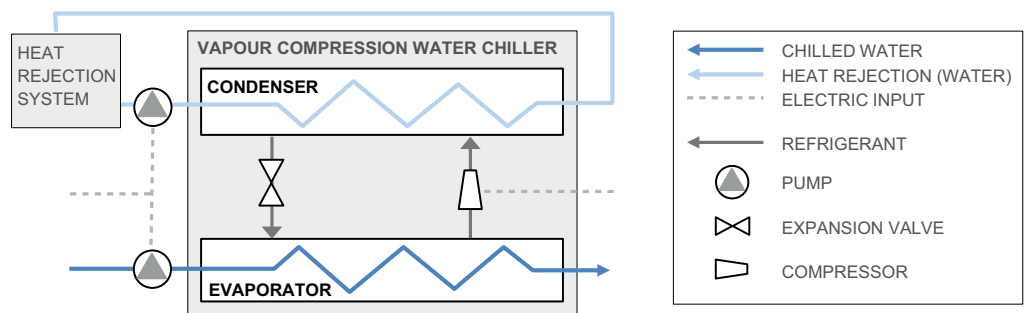

FIG. 4.3 Functioning scheme of a conventional vapour compression air-conditioning system



There are several technologies based on vapour compression; these are categorised into four basic types of air conditioning systems according to their heat transfer medium: all-air systems, all-water systems, air and water systems, and direct refrigerant systems (Daniels, 2003; Lechner, 2014). In all-air systems, air is directly cooled and delivered by ducts, while in all-water systems, water (or another liquid such as glycol) is chilled and then delivered through pipes. Air and water systems refer to the combined use of both systems in order to fulfil cooling requirements, usually relying on an all-water system to handle the bulk of the cooling. Finally, direct refrigerant systems consist of refrigeration machines and two fans to deliver cool air indoors and to reject heat to the external environment. In practical terms, direct refrigerant systems use air as the transfer medium, but they deliver cooling directly, without the use of ducts from a centralised refrigeration machine. In that respect, they could be regarded as all-air systems as well, with the only difference being that they are de-central systems. Typical systems for building applications derived from each technology are shown in Table 4.1.

HEAT TRANSFER MEDIUM		AIR	WATER
<b>Cooling generation</b>	Central application	- Direct expansion systems (rooftop units)	- Chilled water systems (chillers)
	Decentral application	- Window units - Split systems	-
<b>Cooling distribution</b>		Air ducts / Fans	Hydronic systems /Pumps
<b>Cooling delivery</b>	Air cooling	- Diffusers	- Fan-coil units - Induction units
	Surface cooling	-	- Embedded pipes (thermally activated building systems) - Mounted pipes (chilled ceilings) - Capillary tubes

TABLE 4.1 Common technologies based on vapour compression air-conditioning

#### 4.2.2 Alternative Cooling Systems: Heat-Driven Cooling Cycles

Alternative systems for space cooling can potentially replace vapour compression technologies, lowering energy consumption while eliminating the need for harmful substances used as refrigerants. Some explored alternatives are sorption, desiccant, magnetic, thermo-acoustic, thermoelectric, and transcritical CO<sub>2</sub> cooling (Brown & Domanski, 2014). All these technologies consider specific components and could be promising alternatives in the future based on further development; however, this review will focus on two of the most mature ones, with current application possibilities in the built environment: sorption and desiccant cooling.

These technologies use heat as the main driver of distinct refrigeration cycles, only requiring electricity for minor auxiliary equipment such as pumps and fans. The potential use of heat, a low-grade energy,

as the main driver for cooling has attracted researchers' attention over the years, promoting alternatives based on the re-use of waste heat, or solar energy through thermal collectors. Nowadays, solar thermal cooling is a well-established research field that explores solar driven sorption and desiccant technologies with countless research projects, prototypes, and systems developed for commercial application in buildings. Similar to vapour compression systems, sorption cooling is based on the basic refrigeration cycle, which results from the continuous evaporation and condensation of a particular refrigerant. However, in sorption cooling, the mechanical compressor unit is replaced by a 'thermal compressor' unit that drives the cycle using heat from an external source (Henning, 2007). The cooling effect is obtained with a working pair of refrigerant and sorbent. The refrigerant evaporates in the evaporator, extracting indoor heat. It is then mixed with the sorbent and consecutively separated, to end up being condensed again, rejecting the extracted heat outside.

There are two distinct technologies under this basic principle, defined by the type of sorbent used. Absorption heat pumps use a liquid solution as sorbent, while adsorption heat pumps use solid sorption materials. Both technologies commonly use water as the main refrigerant, as well as a heat transfer medium for cooling distribution on a closed cycle (Fig. 4.4). Therefore, complementary distribution and heat rejection components must be considered next to a parallel ventilation system to bring fresh air into the building. Absorption chillers represent a mature technology (OECD/IEA, 2012), commercially available across a wide range of cooling capacities from 4.5 to over 20.500kW. Adsorption systems are less frequently used due to lower efficiencies and intermittent operation. However, they do not rely on moving parts in their working cycle, which simplifies maintenance and offers noiseless operation (Balaras, Grossman, Henning, Infante Ferreira, Podesser et al., 2007)

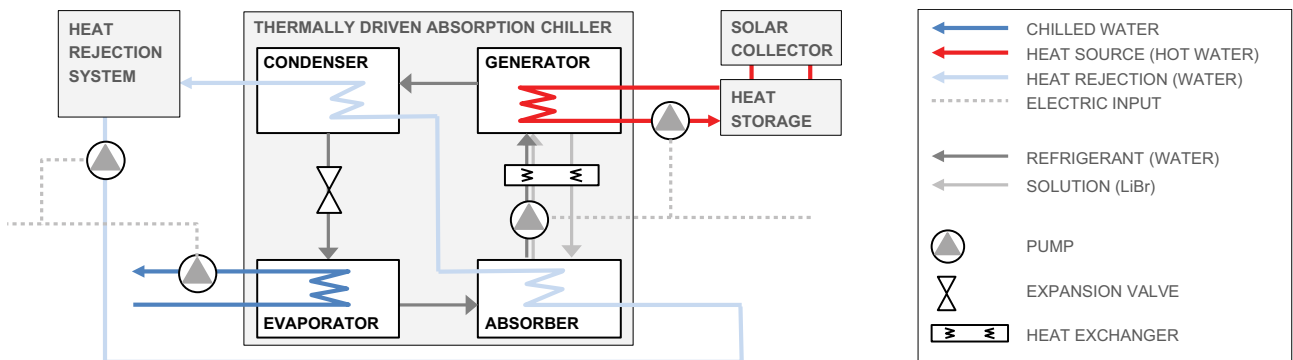

FIG. 4.4 Functioning scheme of a solar driven absorption chiller

Desiccant cooling technologies are also sorption-based, using a working pair of refrigerant and sorbent materials. However, while sorption cooling works in closed systems, desiccant systems provide conditioned air directly into the building, under an open-ended process.



## 4.3 Electricity

With appliances accounting for 11% of the total energy used in residential buildings and lighting for 10% of electricity consumption (Fig. 4.6), considering this share of energy use during the design phase can have benefits in the overall energy performance of the building.

### 4.3.1 Artificial Lighting and Appliances

Increasing the efficiency of lighting and appliances is the first step to reduce the energy use. Directives on eco-design (DIRECTIVE, 2009/125/EC) and energy labelling of products (DIRECTIVE, 2010/30/EU) provide the regulatory framework. Apart from the products' efficiency, which is provided by the manufacturer, the usage patterns determine the energy use, which can be improved by better and smarter systems control.

### 4.3.2 Daylight

Apart from passive heating, the sun can be used for daylight to reduce the need for electric lighting. Daylight is the preferred form of illumination in buildings. The human eye has evolved using it, and its full spectrum output means it delivers better colour rendering properties than any other light source (Hall, 2008b). Most importantly, with the energy use for lighting being 10% of total electricity consumption in dwellings (Bertoldi et al., 2012) and up to 30% in high-rise office buildings (Wood & Salib, 2013), the use of daylight instead of electrical lighting can drastically reduce the energy demand.

The amount of sun radiation used for both passive solar heating and daylight admitted in the space depends primarily on the amount of transparent and translucent areas of the façade. Additionally, the building orientation, shading and reflectance of the surrounding buildings, and weather condition are influential (Hausladen et al., 2008).

### 4.3.3 Electricity Generation (RES)

In contrast to energy produced from fossil fuel, such as oil or gas, renewable energy is tapping into natural processes, such as sun radiation, wind, water movement etc., processes that are perpetually repeated. Both electricity and heat can be generated by renewable energy sources. Renewable energy production includes geothermal and biomass, which were discussed in previous sections, as well as solar, wind, and hydro power. According to Eurostat (2016), the share of renewables in electricity consumption is growing. In the scope of this chapter, we discuss renewable energy production technologies that



FIG. 4.7 Photovoltaic cells integrated into the glass panels on the roof of Akademy Mont-Cenis in Stadtteilpark Mont-Cenis in Herne, DE

are more commonly used on a building scale, which are photovoltaic panels, also often referred to as Building integrated photovoltaic (BIPV), and small-scale wind turbines.

Photovoltaic (PV) assemblies are technical systems that transform radiation directly into electricity. At the core of the installation, there are solar cells, combined into modules that produce DC voltage (Schittich, 2006). Typical PV cells are mostly composed of crystalline silicon cells, either formed in a single or multi-crystalline structure. The second generation of PV cells consisted of thin-film cells, made from different semiconductor materials; while novel developments such as organic solar cells or polymer cells have been branded as emerging technologies or 'third generation' cells. These refer to technologies which have been developed past the 'proof-of-concept' phase, but further research is needed to allow for widespread commercial application (Munari-Probst & Roecker, 2012). Electricity from photovoltaic modules can be fed to the electricity network, or can cover electricity demand on site.

The annual output of the PV system is also determined by the orientation and the angle of the module surface. For northern Europe, the highest annual radiation is for south-facing systems at an angle of 30°. The performance significantly decreases on vertical surfaces. However, generally speaking, the available building façade area is considerably larger than the roof space of a building. Thus, incorporating PVs in façade design results in more electricity production. R&D experiences have been driven by the evaluation of new concepts such as photovoltaic double-skin façades and PV integrated shading devices, or the exploration of specific attributes such as semi-transparent PV glazing, or colour customisation possibilities for solar modules. The task of integrating the PVs into the building skin is integral. The visual and constructional integration must guarantee that the installation does not conflict, but complements the requirements and characteristics of the building skin.

Wind turbines use the kinetic energy of the air to rotate their blades, which turns a generator, producing electricity. Wind turbines can be freestanding on their tower, or can be attached to buildings. Nevertheless, the latter is still not commonly used, as it can be more advantageous to place them near rather than on buildings (Hall, 2008b). Building-integrated turbines, where buildings are designed with wind energy in mind, are an option for consideration by developers tuned into the change surrounding sustainable living (Bobrova, 2015).

## 5 **Conclusions**

This chapter presented passive and active measures that are in line with environmental or bioclimatic design principles, aiming at buildings that provide thermal comfort with minimum or no use of non-renewable energy sources. Within this framework, the main actions come down to preventing/minimising the energy demand for heating and cooling and an efficient use of energy from renewable sources. These actions do not compete but rather interact with and complement each other. Thus, the design should consider them in parallel and should not neglect any step.

The discussed measures have been summarised in Fig. 2.2 and they are linked to how the heat is treated by the building envelope and building systems. Passive measures result in heat protection, heat gain from the sun and heat rejection, while active measures are related to heat dissipation and energy generation.

Ultimately, the energy use in the building is related to the users' wishes and behaviour. The measures described in the present chapter primarily affect the building-related energy demand, such as heating, cooling, and ventilation, with the user's satisfaction naturally being a precondition. User-related energy demand, such as energy used for appliances, lighting, and hot water, is not directly influenced by the building design. However, some of the measures discussed, such as electricity generation or the design for daylight, can contribute to reducing this energy consumption.

The environmental design principles can be beneficial to building performance, whether the design ambition is to have a comfortable and functional building with reasonable energy demand or go as far as achieving sustainable standards such as zero-energy or passive house.

The choice of measures is ultimately a design choice that will affect the architectural quality and expression of the building, as well as its function. The climate and local environmental elements should be considered, but the decision cannot be based on that alone, as every design needs to consider many parameters. The objective of providing the passive and active measure overview is not to give a prescription but provide knowledge to designers.

## References

- Abdallah, A. S. H., Yoshino, H., Goto, T., Enteria, N., Radwan, M. M., & Eid, M. A. (2013). Integration of evaporative cooling technique with solar chimney to improve indoor thermal environment in the New Assiut City, Egypt. *International Journal of Energy and Environmental Engineering*, 4(1), 1-15. Retrieved from <http://www.scopus.com/inward/record.url?eid=2-s2.0-84891437435&partnerID=40&md5=fa3168f3c15c49ae5b901811f2835c49>
- Abu Khadra, A., & Chalfoun, N. (2014). Development of an integrated passive cooling façade technology for office buildings in hot arid regions. *WIT Transactions on Ecology and the Environment*, 190 VOLUME 1, 521-534. Retrieved from <http://www.scopus.com/inward/record.url?eid=2-s2.0-84897866302&partnerID=40&md5=25fb26f4034ea9db643f8d163c678e94>
- AEA. (2010). Green Public Procurement: Thermal Insulation Technical Background Report. Harwell. Retrieved from [http://ec.europa.eu/environment/gpp/pdf/thermal\\_insulation\\_GPP\\_%20background\\_report.pdf](http://ec.europa.eu/environment/gpp/pdf/thermal_insulation_GPP_%20background_report.pdf)
- AgentschapNL. (2013). *Infoblad Trias Energetica en energieneutraal bouwen*. In A. M. v. E. Zaken (Ed.). Utrecht. Retrieved from <http://www.agentschapnl.nl/content/infoblad-trias-energetica>
- Ala-Juusela, M. e. (2003). LowEx guidebook: low-exergy systems for heating and cooling of buildings. *Guidebook to IEA ECBCS annex 37*. Birmingham, UK: ECBCS Bookshop.
- Artmann, N., Manz, H., & Heiselberg, P. (2007). Climatic potential for passive cooling of buildings by night-time ventilation in Europe. *Applied Energy*, 84(2), 187-201. Retrieved from doi:<http://dx.doi.org/10.1016/j.apenergy.2006.05.004>
- Balaras, C. A., Grossman, G., Henning, H.-M., Infante Ferreira, C. A., Podesser, E., Wang, L., & Wiemken, E. (2007). Solar air conditioning in Europe—an overview. *Renewable and Sustainable Energy Reviews*, 11(2), 299-314. Retrieved from doi:10.1016/j.rser.2005.02.003
- Bertoldi, P., Hirtl, B., & Labanca, N. (2012). *Energy Efficiency Status Report 2012: Electricity Consumption and Efficiency Trends in the EU-27 Italy*. Retrieved from
- Bobrova, D. (2015). Building-Integrated Wind Turbines in the Aspect of Architectural Shaping. *Procedia Engineering*, 117, 404-410. Retrieved from doi:<http://dx.doi.org/10.1016/j.proeng.2015.08.185>
- BPIE. (2011). *Europe's buildings under the microscope*. Brussels: Building Performance institute Europe. Retrieved from [http://www.bpie.eu/eu\\_buildings\\_under\\_microscope.html](http://www.bpie.eu/eu_buildings_under_microscope.html)
- Brown, J. S., & Domanski, P. A. (2014). Review of alternative cooling technologies. *Applied Thermal Engineering*, 64(1-2), 252-262. Retrieved from doi:10.1016/j.applthermaleng.2013.12.014
- CICA. (2002). *Industry as a partner for sustainable development-Refrigeration*. UNEP. Retrieved from
- CISBE. (2005). *Guide B: Heating, ventilating, air conditioning and refrigeration*. London: The Chartered Institution of Building Services Engineers
- Daniels, K. (2003). *Advanced Building Systems: A Technical Guide for Architects and Engineers*. Birkhäuser. Retrieved from <https://books.google.nl/books?id=xwPGLyS0C>
- DIRECTIVE. (2009/125/EC). establishing a framework for the setting of ecodesign requirements for energy-related products. Brussels: THE EUROPEAN PARLIAMENT AND OF THE COUNCIL.
- DIRECTIVE. (2010/30/EU). on the indication by labelling and standard product information of the consumption of energy and other resources by energy-related products. Brussels: THE EUROPEAN PARLIAMENT AND OF THE COUNCIL.
- Emmanuel, R., & Baker, K. (2012). *Carbon Management in the Built Environment*. Abingdon: Routledge. Retrieved from [http://books.google.nl/books?id=udjGcf\\_BkPIC](http://books.google.nl/books?id=udjGcf_BkPIC)
- EN15242. (2007). Ventilation for buildings - Calculation methods for the determination of air flow rates in buildings including infiltration. European Committee for Standardization (CEN).
- EN15316-4-2. (2007). Heating systems in buildings - Method for calculation of system energy requirements and system efficiencies - Part 4-2: Space heating generation systems, heat pump systems: European Committee for Standardization (CEN).
- EN15316-4-4. (2007). Heating systems in buildings - Method for calculation of system energy requirements and system efficiencies - Part 4-4: Heat generation systems, building-integrated cogeneration systems: European Committee for Standardization (CEN).
- Entrop, A. G., & Brouwers, H. J. H. (2010). Assessing the sustainability of buildings using a framework of triad approaches. *Journal of Building Appraisal*, 5(4), 293-310. Retrieved from [http://www.researchgate.net/publication/43643981\\_Assessing\\_the\\_sustainability\\_of\\_buildings\\_using\\_a\\_framework\\_of\\_triad\\_approaches](http://www.researchgate.net/publication/43643981_Assessing_the_sustainability_of_buildings_using_a_framework_of_triad_approaches)
- Eurostat. (2016). *THEME 6: CLIMATE CHANGE AND ENERGY. SUSTAINABLE DEVELOPMENT INDICATORS*. Retrieved from <http://ec.europa.eu/eurostat/web/sdi/indicators/climate-change-and-energy>
- Ferrari, S., & Zanotto, V. (2012). Office Buildings Cooling Need in the Italian Climatic Context: Assessing the Performances of Typical Envelopes. *Energy Procedia*, 30(0), 1099-1109. Retrieved from doi:<http://dx.doi.org/10.1016/j.egypro.2012.11.123>
- Geros, V. S., M; Tsangrasoulis, A; Guarracino, G. (1999). Experimental evaluation of night ventilation phenomena. *Energy and Buildings*, 29, 141-154.
- Giebeler, G. (2009). *Refurbishment manual: maintenance, conversions, extensions*. Basel: Birkhäuser. Retrieved from [http://aleph.tudelft.nl:80/F/?func=direct&doc\\_number](http://aleph.tudelft.nl:80/F/?func=direct&doc_number)
- Givoni, B. (1994). *Passive Low Energy Cooling of Buildings*. Wiley. Retrieved from <https://books.google.com.ec/books?id=rJsVoRw1ge0C>

- greenspec. (2013). *Energy-efficient house refurbishment / retrofit*. Retrieved from <http://www.greenspec.co.uk/>
- Hall, K. (2008a). *Green Building Bible Vol.1 (4 ed. Vol. 1)*. Green Building Press. Retrieved from <http://books.google.nl/books?id=BsCFAAAACAAJ>.
- Hall, K. (2008b). *Green Building Bible Vol.2 (4 ed. Vol. 2)*. Green Building Press. Retrieved from <http://books.google.nl/books?id=BsCFAAAACAAJ>.
- Hausladen, G., Saldanha, M. d., & Liedl, P. (2008). *Climateskin : building-skin concepts that can do more with less energy (Vol. mo0809new-0903-1v-plh shared)*. Basel; Boston: Birkhäuser.
- Hegger, M., Fuchs, M., Stark, T., & Zeumer, M. (2008). *Energy Manual: Sustainable Architecture*. Basel, Switzerland: Birkhäuser. Retrieved from [http://books.google.nl/books?id=zK\\_7PAAA-CAAJ](http://books.google.nl/books?id=zK_7PAAA-CAAJ).
- Henning, H.-M. (2007). Solar assisted air conditioning of buildings – an overview. *Applied Thermal Engineering*, 27(10), 1734-1749. Retrieved from doi:<http://dx.doi.org/10.1016/j.applthermaleng.2006.07.021>
- Herzog, T., Krippner, R., & Lang, W. (2004). *Façade Construction Manual*. Basel: Birkhäuser. Retrieved from [http://books.google.nl/books?id=TTG\\_ZzlvVuAC](http://books.google.nl/books?id=TTG_ZzlvVuAC).
- Hyde, R. (Ed.) (2008). *Bioclimatic housing : innovative designs for warm climates*. London: Earthscan.
- ISO10077-2. (2006). Thermal performance of windows, doors and shutters - Calculation of thermal transmittance - Part 2: Numerical method for frames: European Committee for Standardization (CEN).
- Kalz, D., & Pfafferoth, J. (2014). *Thermal Comfort and Energy-Efficient Cooling of Nonresidential Buildings*. Springer International Publishing. Retrieved from <https://books.google.nl/books?id=ohu4BAAAQBAJ>.
- Karanouh, A., & Kerber, E. (2015). *Innovations in dynamic architecture*. Journal of Facade Design and Engineering, 3(2), 37. Retrieved from doi:10.7480/jfde.2015.2.1017
- Knaack, U., Klein, T., Bilow, M., & Auer, T. (2007). *Façades principles of construction*. Basel: Birkhäuser. Retrieved from [http://aleph.tudelft.nl:80/F/?func=direct&doc\\_number](http://aleph.tudelft.nl:80/F/?func=direct&doc_number).
- Kohlenbach, P., & Jakob, U. (2014). *Solar Cooling: The Earthscan Expert Guide to Solar Cooling Systems*. Taylor & Francis. Retrieved from <https://books.google.nl/books?id=3LzcAwAAQBAJ>.
- Konstantinou, T. (2014). *Facade Refurbishment Toolbox: Supporting the Design of Residential Energy Upgrades*. (PhD): Delft University of Technology. Retrieved from <http://abe.tudelft.nl/index.php/faculty-architecture/article/view/konstantiou>
- Lechner, N. (2014). *Heating, Cooling, Lighting: Sustainable Design Methods for Architects*. Wiley. Retrieved from <https://books.google.nl/books?id=WjetCwAAQBAJ>.
- Lyons, A. (2010). *Materials for Architects and Builders*. Elsevier Science. Retrieved from <http://books.google.nl/books?id=T1jVKyQE78C>.
- McMullan, R. (2002). *Environmental science in building*. Basingstoke: Palgrave. Retrieved from [http://aleph.tudelft.nl:80/F/?func=direct&doc\\_number](http://aleph.tudelft.nl:80/F/?func=direct&doc_number).
- Morgado, I., Melero, S., Neila, J., & Acha, C. (2011). Evaporative cooling efficiency according to climate conditions. *Procedia Engineering*, 21, 283-290. Retrieved from doi:10.1016/j.proeng.2011.11.2016
- Munari-Probst, M. e., & Roecker, C. e. (2012). Solar energy systems in architecture. *Report T.41.A.2 IEA SHC Task 41 Solar energy and Architecture. I. Solar heating & Cooling Programme*. Retrieved from
- Nicol, F., Humphreys, M., & Roaf, S. (2012). *Adaptive Thermal Comfort: Principles and Practice*. New York: Taylor & Francis. Retrieved from <https://books.google.nl/books?id=vE7FBQAAQBAJ>.
- OECD/IEA. (2012). Technology Roadmap - Solar Heating and Cooling. I. E. A. (IEA). Retrieved from: [https://www.iea.org/publications/freepublications/publication/Solar\\_Heating\\_Cooling\\_Roadmap\\_2012\\_WEB.pdf](https://www.iea.org/publications/freepublications/publication/Solar_Heating_Cooling_Roadmap_2012_WEB.pdf)
- Papadopoulos, A. M. (2005). State of the art in thermal insulation materials and aims for future developments. *Energy and Buildings*, 37(1), 77-86. Retrieved from doi:10.1016/j.enbuild.2004.05.006
- Prieto, A., Knaack, U., Klein, T., & Auer, T. (2017). 25 Years of cooling research in office buildings: Review for the integration of cooling strategies into the building façade (1990–2014). *Renewable and Sustainable Energy Reviews*, 71, 89-102. Retrieved from doi:10.1016/j.rser.2017.01.012
- Qi, C. (2006). *Office Building Energy Saving Potential in Singapore*. (Master of Science). Singapore: National University of Singapore (NUS).
- Roach, P., Bruno, F., & Belusko, M. (2013). Modelling the cooling energy of night ventilation and economiser strategies on façade selection of commercial buildings. *Energy and Buildings*, 66(0), 562-570. Retrieved from doi:<http://dx.doi.org/10.1016/j.enbuild.2013.06.034>
- Samuel, D. G. L., Nagendra, S. M. S., & Maiya, M. P. (2013). Passive alternatives to mechanical air conditioning of building A review. *Building and Environment*, 66, 54-64. Retrieved from doi:10.1016/j.buildenv.2013.04.016
- Santamouris, M., & Asimakopoulos, D. (1996). *Passive Cooling of Buildings: James & James*. Retrieved from <https://books.google.nl/books?id=tLHsJ0-vEKYC>.
- Schittich, C. (2006). *In detail: building skins*. Basel: Birkhäuser. Retrieved from [http://aleph.tudelft.nl:80/F/?func=direct&doc\\_number](http://aleph.tudelft.nl:80/F/?func=direct&doc_number).



- SEDBUK. (2005). *Boiler Efficiency Database*. Retrieved from <http://www.boilers.org.uk/>
- Sherman, M. H., & Chan, R. (2004). *Building Airtightness: Research and Practice*. Berkeley. Retrieved from <http://epb.lbl.gov/publications/pdf/lbnl-53356.pdf>
- Smith, P. F. (2005). *Architecture in a climate of change: A guide to sustainable design*. Oxford: Architectural Press. Retrieved from [http://aleph.tudelft.nl:80/F/?func=direct&doc\\_number](http://aleph.tudelft.nl:80/F/?func=direct&doc_number).
- Soltani, M., Chaker, M., Haddad, E., & Kruzelecky, R. (2008). Thermo-chromic vanadium dioxide [VO<sub>2</sub>] smart coatings for switching applications. In *Applied Physics in the 21st Century*. Kerala: Transworld Research Network 37/661 (2),
- Stephen, R. K. (2010). *Airtightness in UK Dwellings: BRE's Test Results and Their Significance*: CRC Press. Retrieved from <https://books.google.nl/books?id=YRcuAAAACAAJ>.
- van den Dobbelaar, A. (2008). Towards closed cycles - new strategy steps inspired by the cradle to cradle approach. in *PLEA Dublin 2008 Towards zero energy building - conference proceedings*,
- Wood, A., & Salib, R. (2013). *Guide to Natural Ventilation in High Rise Office Building*. Abingdon: Routledge. Retrieved from <https://books.google.nl/books?id=2EDFxWb1r5AC>.

